

## TABLE OF CONTENTS

|   |       |
|---|-------|
| NBPI Board of Directors.....                  | 4     |
| NBPI Technical Services.....                  | 4     |
| Membership .....                              | 5     |
| Pulling Divisions and Classes.....            | 6     |
| Class Weights .....                           | 7     |
| Hook Fees / Points.....                       | 8     |
| Ties / Protest and Rule Violations .....      | 9     |
| General Sled Rules.....                       | 10    |
| General Rules / Contest Procedures.....       | 11-13 |
| A - Reasons for Disqualification .....        | 14    |
| B - Safety Rules .....                        | 15-16 |
| Pro Pulling League Safety Rules .....         | 17-25 |
| General Truck Rules .....                     | 26    |
| A - Limited Pro Diesel 4X4 Pick-Up Trucks.... | 26-29 |
| B - Pro Stock Pick-Up Trucks .....            | 30-33 |
| General Tractor Rules.....                    | 34-37 |
| A - Super Field Tractors.....                 | 38    |
| B - 466 Limited Pro Stock Tractors .....      | 39    |
| C - Super Farm Tractors .....                 | 40    |
| D - Light Super Stock Tractors.....           | 41-42 |
| E - 640 Limited Pro Stock Tractors .....      | 43    |
| F - Unlimited Super Stock Tractors .....      | 44    |
| General Modified Rules.....                   | 45    |
| A - Modified Tractors.....                    | 45-46 |
| B - Turbine Modifieds .....                   | 47-48 |
| Stabilizer (Wheelie) Bars.....                | 49    |
| Drawbar Rules / Drawing .....                 | 50    |
| NBPI By-Laws.....                             | 51-58 |

# NEBRASKA BUSH PULLERS, INC.

## COMMITTEES

---

### BOARD OF DIRECTORS

**Joel Soulliere, President**

3965 30th Ave  
Columbus, NE 68601  
402-276-1352

**Bowdie Otte, Vice President**

55928 843 Road  
Norfolk, NE 68701  
402-750-5678

**Brian Fuhr, Secretary**

12417 505 Street  
Leigh, NE 68643  
402-920-1915

**Gary & Lynn Remmers,  
Treasurer**

3563 E. Locust Lane  
Holmesville, NE 68310  
402-230-0059  
402-223-8308

**Arlin Pomajzl, COB**

1205 Qunice Ave  
Crete, NE 68333  
402-826-3941

**Martin Sousek, Tech Director**

1610 32nd Road  
David City, NE 68632  
712-840-1622

**Lucas Oil Pro Pulling League**

P.O. Box 287  
Brownstown, IN 47220  
812-216-4024

### DIVISIONAL DIRECTORS

Rodney Jedlicka, **Super Farm**  
402-615-0182

Mike Langan Jr., **Light S.S.**  
402-910-6949

Blake Otte, **Modified**  
402-750-6763

Darin Weers, **95 Lim. Pro**  
402-793-5167

Kurt Bohaboj, **Unl. S.S.**  
402-699-5826

Todd Jarecke  
**Limited Prostock Diesel**  
402-570-0780

Billy Ruwe, **Super Field**  
402-533-3380

Erik Falk, **Pro Stock Trucks**  
402-981-6935

Kenton Kabes, **85 Lim. Pro**  
402-276-7666

Zach Kabes, **85 Lim. Pro**  
402-276-4994

# NEBRASKA BUSH PULLERS, INC. RULES

## NBPI MEMBERSHIP

1. Membership is open to anyone that follows the Nebraska Bush Pullers rules along with the Pro Pulling League safety rules.
2. Insurance is to be paid to the Lucas Oil Pro Pulling League Office \$225 per person and \$225 per pulling vehicle. Nebraska Bush Pullers membership is \$50.00 with a \$20 per hook fee. Insurance and membership is to be postmarked by March 1st or you may be subject to higher rates.
3. Membership fee includes dues and newsletter. It must be paid before you pull.
4. Four pit passes per certified tractor will be given. Passes issued when tractor is being certified.
5. Old members must be signed up by March 1st. After March 1st a \$15.00 extra fee will be charged.
6. Insurance is required to pull and must be paid before you pull. This is per member. It provides \$10,000,000 in general liability limits.
7. You must be a current member to vote on any NBPI decisions. Only competing members are allowed to vote on track and equipment rule changes. Competing members is defined as a member who hooked a tractor a minimum of three times during the season (hooks in three different classes or at three pulls).
8. Voting during the rules meeting will be as follows: Vote together as a group on general, membership, track and pull rules. All discussion on equipment rules will be done together, but voting will be done separately according to the type of vehicle you have (Super Stock votes on Super Stock equipment rules, Super Farm votes on Super Farm rules etc.).
9. One vote per vehicle.

## PULLING DIVISIONS AND CLASSES

The NBPI has 9 classes of competition to offer, order of each pull is subject to change! Event Officials and Sled Operators are to determine the class order no less than 30 minutes before start time.

1. Super Farm Tractors (SF)
2. Light Super Stock Tractors (LSS)
3. Limited Pro Stock Diesel
4. Modified Tractors (MOD)
5. 9500 Limited Pro Stock Tractors (95 LPS)
6. Unlimited Super Stock Tractors (USS)
7. 3000 RPM 466 Hot Farm Tractors (466)
8. Pro Stock Pick-Up Trucks (PRO 4X4)
9. 8500 Limited Pro Stock Tractors (85 LPS)

There will be no class jumping, if your class is not offered you can only move up in classes. Example- Super Farm to Limited Pro Stock, Light Super Stock to Unlimited Super Stock.

## CLASS WEIGHTS

| CLASS                       | WEIGHT    |
|-----------------------------|-----------|
| ***Automotive Type Modified | 6000 lbs. |
| Turbine Type Modified       | 6200 lbs. |
| ***Light Super Stock        | 6400 lbs. |
| ***Unlimited Super Stock    | 6500 lbs. |
| Limited Diesel 4x4 Trucks   | 8000 lbs. |
| ***3000 RPM 466 Hot Farm    | 8200 lbs. |
| ***Super Farm               | 9200 lbs. |
| 640 c.i.Limited Pro Stock   | 9500 lbs. |
| Pro Stock Pick-Up Trucks    | 6200 lbs. |
| 466 c.i.Limited Pro Stock   | 8500 lbs. |

**NOTE:** (\*\*\*) - Weight is subject to the following conditions:

**AUTOMOTIVE TYPE MODIFIED:** Single engine N/A up to 710 cubic inch tractors can weight 7200 lbs.

**466 HOT FARM and SUPER FARM:** Must have a minimum of 200 lbs. moveable weight. 466 Cubic Inch Hot Farm, any 3x4 charger without slug any diesel and water can weigh up to 9500 lbs. in the Super Farm class.

**LIGHT SUPER STOCK:** 640 ci. 4.8-inch turbo diesel, 505 multi charger diesel, 505-alcohol single charger, and 370 ci. or less twin charger alcohol will weigh 6400 lbs.

371-505 ci. multi charger alcohol will weigh 6100 lbs.

All Light Super Stock Tractors will be allowed 100lbs. of moveable weight for smoke tube at indoor events.

**UNLIMITED SUPER STOCK:** Component tractors will weigh 6500 lbs. Cast Rear-end tractors will weigh 7500lbs.

Tractors running under the Nebraska Truck & Tractor Pullers Limited Pro Stock rules will be allowed 300 lbs. additional weight in the Super Farm class.

## ONE TIME HOOK FEE

1. A one-time hook fee of \$100.00 will be paid the day of the pull.
2. Vehicles will receive no points for a one-time hook.

## POINTS

1. A points system is kept to determine the yearly champion in each of the classes. Points are given to the vehicle, regardless of the number of team members. Points are awarded as follows:

1<sup>st</sup> Place – 10 Pull Points + 5 Hook Points = 15 Points

2<sup>nd</sup> Place – 9 Pull Points + 5 Hook Points = 14 Points

3<sup>rd</sup> Place – 8 Pull Points + 5 Hook Points = 13 Points

4<sup>th</sup> Place – 7 Pull Points + 5 Hook Points = 12 Points

5<sup>th</sup> Place – 6 Pull Points + 5 Hook Points = 11 Points

6<sup>th</sup> Place – 5 Pull Points + 5 Hook Points = 10 Points

7<sup>th</sup> Place – 4 Pull Points + 5 Hook Points = 9 Points

8<sup>th</sup> Place – 3 Pull Points + 5 Hook Points = 8 Points

9<sup>th</sup> Place – 2 Pull Points + 5 Hook Points = 7 Points

10<sup>th</sup> Place – 1 Pull Points + 5 Hook Points = 6 Points

Each Tractor after 10<sup>th</sup> Place will receive 5 Hook Points

2. Hook points will be awarded even if disqualified in your class. NO money paid out on disqualifications.

## TIES

1. If there is a tie, points and money for that place and that after it will be combined and split evenly. For example, a tie for 1st place would score 1st & 2nd place money and points, combined and split evenly.

## PROTEST AND RULE VIOLATIONS

1. A protest of one competing member against another competing member requires a \$500.00 deposit up front. All protest must be made within 15 minutes of completion of event.
2. First contact a tech official or rules officer. Item protested will be checked and either puller or protester will receive money. This goes for protest of any type, i.e., equipment, rules, fuels (fuel sample to be taken and tested at independent lab, at loser's expense), for any other protest.
3. To protest a modified tractor under the cubic inch rule, contact a tech official or modified rules officer. Protester and driver being protested must first put up \$250.00 each. On a protest, all tractors will be checked if the tractor being protested fails the test.
4. For rule violations the penalty will be:
  - A. 1<sup>st</sup> violation – lose points and money for that day.
  - B. 2<sup>nd</sup> violation – banned from the association for one year plus 1 day from the date of the violation.

**NOTE:** Judges decisions are final! There is NO appeal process. Disagreement will result in disqualification.

## GENERAL SLED RULES

1. All weight transfer sleds used by the Nebraska Bush Pullers Inc. and at sanctioned NBPI pulls must have passed a safety inspection and licensed by the North American Sled Operators Association – NASOA or NBPI.
2. All sleds must be a mechanical device with operator on sled when in operation. All sleds also must have workable brakes with a red light that comes on when brakes are applied.
3. Chain length on all large sleds must be 46 inches long (plus or minus ½ inch).
4. All sleds must have a primary and secondary chain that will be used at all NBPI events.
5. Race sleds will be used at all pulls.
6. No weights, brackets, braces or any other portion of the vehicle may interfere with the hooking and unhooking of the sled or interfere with the chain during the pull.



## GENERAL RULES / CONTEST PROCEDURES

1. All Drivers must be at least 16 years of age. If under 18 years of age they must have a parent or guardian consent.
2. All drivers and crewmembers must act in a sensible manner. If not, after one warning, they will face possible expulsion from the organization.
3. A floating finish will be used at all events.
4. Certification of vehicle is required. Vehicle must be weighed with full fuel, water and oil levels, as the vehicle would compete on the track. Reservoirs and kill switches will be checked at this time. There will be inspection of all safety equipment and other vehicle components. Levels are subject to be checked at other time by a rules officer or tech official. One board member must supervise certification and one member other than yourself, Vehicle along with driver, must be certified before you pull.
5. Vehicle and driver must not exceed weight class. Any tire change requires re-certification of vehicle. There will be a scale at every NBPI event and every vehicle competing will be weighed and then immediately proceed to the pull staging area.
6. If a rules officer or tech official feels a puller is illegal, that person has the right to check any vehicle at any time without the protest rule. If a general member or puller has a protest, then the protest rule applies.
7. During the pull, safety is always in the front of everybody's mind. The crowd must be kept a minimum of 30 feet from the track area in all directions. Spectators in the pit area are to be kept to a minimum. The ends of the track must be kept open at all times. The NBPI will not operate any pull at which a safety hazard is posed to anyone.

8. Each vehicle will only be allowed to pull in one class, with a \$20.00 hook fee to be paid before you pull.
9. All vehicles must leave the track under their own power, unless broken down.
10. Track must be, if possible, 300 feet long, or as long as area warrants, with adequate run-off room, and not less than 30 feet wide.
11. A floating finish (no 300ft. full pull, but go until the sled stops) will be used.
12. Pulling vehicle must be operated in a safe manner. Operator must remain in the seat during the pull attempt and must have complete control. Officers and Officials have the right to disqualify any driver that cannot handle his/her vehicle in a safe and orderly manner.
13. Driver only is allowed on/in the vehicle while it is "moving". No riders allowed while hooked to the sled, on the track, driving to or from the track.
14. Each puller has the privilege of, and the responsibility for, spotting the sled. Sled operator must be notified when, or before, previous tractor unhooks from the sled.
15. Vehicle must be entered in the class the competitor is going to compete in before the pull starts, unless the officials are agreeable as to for the lateness of the competitor. Each puller will have to draw a number in the class he/she wishes to pull in. If a puller arrives too late to draw for their class they will be assigned a position. All competitors must be entered 30 minutes before the pull begins.
16. Vehicle and driver will have 3 minutes to get to the sled after it has backed up into position, unless track conditions don't allow for it.

17. Vehicle must be stop immediately upon signal from flagman, or stopped by sled. The pull shall be considered over when forward motion stops.
18. Number one puller will be the test puller and may take their pull if the sled setting is acceptable. To receive first puller options, the vehicle must hook to the sled and attempt a pull. If the puller refuses that pull, they can go to either fourth or last position. Choice must be made before unhooking from the sled.
19. All class restarts will be up to the discretion of the track officials.
20. If the puller wishes to make a second attempt, they must attempt to stop or not be under power by the 100ft mark (If the driver attempts to stop within 100 ft. but goes past to avoid being bumped by the sled. The puller will be allowed a re-pull). The second attempt must be made at that time unless vehicle is broken. If broken and repairs can be made, you may come back at the end of the class for your second attempt. Puller may not move any weight or competitor will be disqualified. (An attempt is defined as moving the sled a measurable distance.)
21. On a restart of a class the original first puller has the option of being the first puller or drop to fourth or last. It will be the responsibility of the first puller to remain at the track until the decision is made by the track official's whether to continue or restart a class. At this time the first puller will decide whether to remain first hook drop to fourth or last.
22. Mandatory drawbar height check will be done at the scales at the beginning of the track before each pull attempt. This applies to all NBPI trucks and tractors.
23. No drinking of alcoholic beverages by participating vehicle drivers or track officials.

## A - REASONS FOR DISQUALIFICATION

**NOTE:** Judges decisions are final! There is NO appeal process. Disagreement will result in disqualification.

24. Loss of ballast weight while hooked to the sled will result in disqualification.
25. Loss of safety equipment and/or failure of safety equipment to function.
26. Any vehicle in pit area, staging area or track left running without operator in the seat.
27. Excessive loss of fluid onto the track by the pulling vehicle, while in forward motion, during a contest, will be cause for disqualification, unless due to internal breakage. All discharge tubes must vent outside the frame rails in track of rear tires or into a container. **NOTE:** Excessive is defined as any steady or intermittent stream of discharge onto or a spot equivalent to more than 8' in diameter.
28. A warning will be issued from the track official if there is excessive liquid spilled on the track. If the problem is not corrected before the next event you will be disqualified.
29. If the vehicle goes out of bounds, the vehicle is disqualified unless vehicle's hook is the test position. Out of bounds is only defined within 300 feet.
30. Any illegal equipment will be cause for disqualification
31. Any unsportsmanlike conduct will not be tolerated.
32. No illegal fuels will be allowed (Nitro methane, Nitrous oxide, or any other oxygen carriers.)
33. Leaving the start line under a red flag will be terms for disqualification
34. Violation of any other rule (equipment, weight, track, etc.) will be cause for disqualification.

## B - SAFETY RULES

35. If the vehicle is running, a qualified operator must be in the driver's seat.
36. Helmets must be worn when driving onto the track and while the vehicle is hooked to the sled. Chinstrap must be fastened. All helmets must meet or exceed Snell 90 rating or must be SFI SPEC 31.1, 31.2, 41.1, 41.2. No modifications or alterations of the helmet are allowed. Helmets with flame retardant lining and a flame retardant neck skirt are allowed. If you are using a helmet with flame retardant lining and flame retardant neck skirt, no head sock is required. NOTE: ONCE A HELMET HAS SUFFERED A SEVERE IMPACT, IT MUST BE REPLACED OR SENT TO THE MANUFACTURER FOR RE-INSPECTION.
37. All vehicles must be equipped with a working fire extinguisher, minimum 2-1/2 dry chemical, or equivalent, located convenient to the driver, or so that it can be reached by a track official (so that driver can reach it while seated on the vehicle.)
38. All weights must be securely fastened to the vehicle or vehicle weight brackets. No loose weights allowed anywhere on the vehicle.
39. A scatter blanket is required. Specifications are listed under general 4x4 truck rules, general tractor rules and general modified rules.
40. All vehicles must be equipped with a transmission reverse light that shall be activated only when the vehicle transmission is shifted into the reverse position. This light shall be white in color, a minimum of 2 inches in diameter, tilted downward toward the hitch area and located within 12 inches of the safety kill switch at the rear of the vehicle.

41. Fire suits required in all classes, minimum of SFI 3.2. In flip top bodied vehicles without a firewall or working doors, the driver will be required to wear an SFI approved suit, fireproof gloves, fireproof head-sock, and fireproof shoes must meet SFI Spec. 3.3.
42. A SFI Spec approved roll cage must be installed on all tractors and be inspected by an NBPI roll cage inspector.
43. Seatbelts must require 16.1 SFI Spec on all tractor driver restraint assemblies and be worn during competition.
44. All tractors are required to have skid plates. Skid plates must be mounted in line with each frame rail extend from center of the front axle forward (on both sides) equal in strength to frame rail material. Skid plate must be securely mounted and braced to the chassis. Skid plate surface to be minimum of 4 inches wide and 12 inches long with a minimum 6 inch curve when measured from the front most rolled edge

*NOTE-* Skid plate must be able to support the weight of the front end when checked with a jack. Maximum ground clearance is bottom of the wheel rim not to exceed 4 inches with front tires in normal operating position.

45. All vehicles are required to have a safety hitch. Safety hitch must be as strong as primary hitch and cannot be connected to the primary drawbar. Safety hitch must be mounted eight (8) inches below primary on all tractors and twelve (12) inches below primary for all trucks.
46. All other safety rules as listed under general class rules and elsewhere apply to all classes.



## LUCAS OIL PRO PULLING LEAGUE SAFETY RULES

***These safety rules will be strictly enforced!  
These rules supersede all NBPI rules!***

1. Any contestant under 18 must have written consent from parent or guardian and prior approval from Pro Pulling League Safety Committee.
2. Contestant may not be allowed to participate for emotional or physical reasons. (I.e. including drinking or illness, etc.)
3. Only driver will be allowed on vehicle when it is being towed or driven. No riders on tow tractors or track equipment will be permitted.
4. Driver must be in driver's seat while engine is running.
5. Vehicle must be in neutral or park while hooking to or unhooking from sled. Driver must also raise hands while hooking or unhooking from sled.
6. Any driver or crew member found under the influence of drugs or using intoxicating agents in the track area will be disqualified. Area is defined as 30 feet within the track.
7. No video taping is allowed closer than 30 feet from track or unless directed by head track official.

8. All pulls will start with a tight chain. No jerking of sled is permitted. Excessive jerking of the sled will result in disqualification.
9. All pulling vehicles must pass a tech inspection and meet all safety requirements before they can pull at any event. The Pro Pulling League retains the right to inspect any vehicle at any time. Refusal will result in disqualification.
10. Fire suits required in all classes, minimum of SFI 3.2. In flip top bodied vehicles without a firewall or working doors, the driver will be required to wear an SFI approved suit. B) Fireproof gloves, fireproof head-sock, and fireproof shoes must meet SFI Spec. 3.3. C) All helmets must meet Snell 90 minimum, or SFI Spec. 31.1, 31.2, 41.1, or 41.2.
11. All pulling vehicles are required to have a minimum of 21/2lb. fire extinguishers. Extinguishers must be within reach of driver.
12. Seatbelts must require 16.1 SFI Spec on all driver restraint assemblies and be worn during competition.
13. All vehicles will have a safety switch. The safety switch will ground the ignition and the electric fuel pumps on spark ignition motors and shut off the air intake to diesel motors.
14. No batteries are allowed inside cab of the vehicle unless they are in a marine battery box and secured to the vehicle frame.
15. All pulling vehicles will have a deadman throttle that will automatically return to the closed position. Throttles will work in a reverse to forward motion, reverse being closed.
16. All pulling vehicles must have a starter interrupter switch that will allow starter engagement only in neutral or park position on a transmission gear selector.



17. All vehicles using a foot throttle must use a top strap.
18. All vehicles using an automatic transmission must have a positive gear lockout.
19. Drivers must be seated and in control of the pulling vehicle any time motor is started or running.
20. All pulling vehicles must have a neutral safety light. A) A white light automotive quality, a minimum of 2 inches in diameter, must be mounted within 30 inches of hooking point. B) A light in the driver's compartment must be operated off the same system. C) Both lights and the starter interrupter switch will be operated off of the shifter lever.
21. Pro Pulling League reserves the right to refuse any competitor the right to attend or participate at any event.
22. Pro Pulling League associated groups or state may set their own limitations, but must run Pro Pulling League safety rules
23. All pulling vehicles will have adequate stopping brakes.
24. All brakes in the driveline will be shielded 360° with 5/16 steel or 3/8 aluminum, around the brake components. Ends must be enclosed in the 1/8 steel or aluminum, no cast metal permitted to be used as part of shield.
25. All tractors and 2WD trucks will have working individual working rear wheel brakes.
26. All 4x4 trucks will have complete working front and rear brakes. Driveline brakes may be permitted.
27. All pulling vehicles will have a wide front end. Front wheels must track within rear wheels.
28. All engines using a clutch flywheel assembly will run a full block saver plate. Material being 1/4: aluminum or 3/16 steel minimum.

29. All automotive type engines using a clutch will use a ¼ inch, one piece SFI 6.1 containment bell housing.
30. One cooling hole will be allowed in the bell housing, one (1) inch maximum diameter. Hole must not be in explosion area of bell housing.
31. No welding will be allowed in the explosion area of the bell housing.
32. No chemical milling permitted.
33. There will be five (5) 3/8 bolts or four (4) ½ bolts to secure bell housing to transmission.
34. All inspection maintenance holes must be no wider than 8 ½ inches and the ends of the holes shall be smoothly and fully radiused to produce an oval shape.
35. Four (4) 3/8 grade 5 or better bolts are required, in the top half of bell housing to block. Six (6) evenly spaced grade 5 or better bolts are required on bottom half of bell housing.
36. Any vehicle using two blown or turbocharged automotive engines, three naturally aspirated or any industrial marine or aircraft engine that is turbocharged or twin staged supercharged on one clutch must have a liner in the bell housing.
37. No cast iron clutch components or flywheels will be permitted. Billet steel, aluminum, or magnesium flywheels will be accepted.
38. Clutches, flywheels and related components must be mounted to engine on vehicles using automotive type engines.
39. All clutches on aviation, marine and industrial engines must be approved by the Pro Pulling League.

40. Pro Pulling League reserves the right to spot check any clutch components at any time.
41. Hitch must be rigid in all directions. Hitch length and height cannot change before, during, or after pull. No cam hitches or cam type rear ends permitted.
42. All vehicles are required a safety hitch. Safety hitch must be as strong as primary hitch and cannot be connected to primary drawbar. Safety hitch must be mounted eight (8) inches below primary on all tractors and twelve (12) inches below primary for all trucks.
43. All drawbars will have an opening minimum of 3 X 3 ½ inches.
44. All classes through 7500# must meet the following requirements: Drawbar must be a minimum of two (2) square inches total material at any point. This will include area of the pin removed; pin will be 7/8 minimum. Must be a steel drawbar, not more than 1 ½ by 1 ½ square stock, nor less than one by one.
45. All classes above 7500# must meet the following requirements: Drawbar must be a minimum of 2 1/2 square inches total material at any point. This will include area of the pin removed; pin will be 15/16 minimum. Must be a steel drawbar, not more than 1 ½ by 1 ½ square stock, nor less than 1 1/4 by 1 1/4.
46. Loops on all driveline must be round.
47. All U-joints must be shielded 360° with 3/8" thick aluminum or 5/16" thick steel. Shield will be six (6) inches long minimum and centered on u-joint. Inside diameter of shield will be no more than two (2) inches larger than u-joint. If aluminum is used on u-joint shield, and 1/8" insert will be put inside of shield at u-joint area six (6) inches wide.
48. All vehicles with planetary rear ends will have the drive line totally enclosed with 5/16" steel or 3/8" aluminum. The inside diameter will not be larger than two (2) inches larger than the largest universal joint. No more than ¼" of driveline will be visible. Bolts holding shield together will be 3/8" grade or better, bolted every two (2) inches or closer.

49. All other vehicles not using planetary rear ends will have loops 360° around driveline two (2) inches away from driveline, made of 3/8" aluminum or 5/16" steel, and spaced every 36 inches.
50. Maximum length of driveline on a modified tractor is 48 inches.
51. 4X4 trucks will have three (3) loops per shaft, evenly spaced on driveline, 3/8" aluminum or 5/16" steel thickness, two (2) inch maximum away from driveline.
52. All intermediate shafts between transmission and transfer case will be totally enclosed in 3/8 "aluminum or 5/16" steel, 1/4" of shaft may be visible.
53. Any input or output may extend more than four (4) inches to a bearing.
54. Shielding on v or y type engines must be from the base of the head to two (2) inches below the crankshaft throw. Frame may be used as all or part of the shield provided it is solid and covers the required area.
55. Shielding on in-line engines will run from hood to two (2) inches below crankshaft throw. Shield must be complete, no holes accepted. Shielding must extend complete length of block and be securely fastened.
56. All engines will have a deflection shield, running the complete length of the block casting. Shield must be securely fastened and must be .060 inch thick. Starters, exhausts, fuel pumps, etc., will not be considered as part of the shield.
57. All side shields must be solid. Shielding will be made of aluminum or steel minimum of .060 inch thick.

58. Engine fans must be completely shrouded with steel 1/16" or thicker. Electric fans excluded.
59. All automotive engines equipped with a harmonic balancer must have balancer that is SFI Spec 18.1 and carry SFI identification.
60. All supercharger drive components will be shielded on top and sides with .060" steel or 1/8" aluminum. Side is defined as to the centerline of bottom pulley. Shield should be wider than drive components.
61. All vehicles using an automotive type supercharger will use aluminum blower studs, SEMA specs 6061 T-6 to secure blower to intake manifold. Blower straps meeting SFI Spec 14.1 or high quality nylon braided straps are required at all events.
62. Carbureted, or injected, marine or aircraft engines using a centrifugal super charger must be shielded as follows:
  1. Shielding will be the same on both sides of the supercharger.
  2. The shield will start at the same at the centerline and extend five (5) inches rearward and eight (8) inches forward.
  3. Notching will be allowed only to fit around necessary components.
  4. On the front edge of the shield there will be a rolled lip, extending inward one inch and at a 90° angle.
  5. Shield will be constructed of 3/8" thick steel and be bolted every two (2) inches or closer with 3/8" grade 5 or better bolts.
  6. Shield to start at bottom of housing and go over top and down the other side.
  7. Superchargers, as specified in rules above, may use a safety blanket with the following properties: 22 ply ballistic nylon or 18 ply Kevlar.

63. All diesel engines will have a manual three-way dump valve installed ahead of the injection pump, to be operated from dash panel.
64. All turbocharged engines must have two (2) 3/8 grade 5 bolts in vertical position of exhaust. Bolts to be installed 90° to each other within one inch of each other.
65. All turbochargers mounted outside normal engine shielding will be shielded in .060" steel. All intercoolers mounted outside of normal engine shielding will be .060 aluminum.
66. Pro-Stock & Limited Pro: In vertical portion of exhaust: 2- 3/8 Grade 5 (minimum) bolts, installed 90° to each other within one inch. In horizontal portion of exhaust: 2- 5/16 Grade 5 bolts, installed 90° to each other within one inch of each other and within 4 inches from exhaust housing flange.
67. All vehicles must have exhaust discharging vertically within ten (10) degrees of plumb.
68. All vehicles will be required to use a kill switch.
69. Kill switch will be securely mounted to the back of the vehicle and have a two (2) inch diameter ring to attach the sled.
70. A tie strap will be used during tech to show vehicles have been teched. A 1/4" hole will be used to securely hold tie strap just above the kill switch. Only if tie strap is broken, decided by head track official, will competitor be given opportunity to pull again.
71. A white safety light is required to indicate that competition vehicle is in neutral during process of hooking or unhooking from sled.
72. Kill switches on diesel motors will have:
  1. Air shut off must be operated from driver seat.
  2. Air shut off will consist of cap or guillotine that closes off air into the engine. The cap or guillotine will be spring loaded.

73. All tractors must have some type of barrier between driver and tire. Barrier must be capable of supporting weight of driver.
74. All vehicles must have a strong and rigid seat.
75. Stabilizer bars must support the weight of the vehicle for the heaviest class it will compete in.
76. Stabilizer pads must not be more than ten (10) inches off the ground.
77. The stabilizer pad must be a minimum of five (5) inches square, with a minimum of 20" allowed from the outside of one pad to the other.
78. Stabilizer bars may be in no way connected to draw-bar assembly.
79. Stabilizer bars must have a brace that extends vertically twelve (12) inches from the rear most tip of the skid pads. There must be a support brace extending inward to frame axle or top of stabilizer bar arms. Vertical brace should extend rearward a minimum of two (2) inches from radius of rear tire.
80. Stabilizer bars are required on all classes, except for 4X4 trucks.
81. The use of torque converters, automatic shifts, etc. will be permitted.
82. All vehicles using an automatic transmission must have an SFI Spec. 29.1 automatic transmission flex plate. No cast iron is permitted.
83. All vehicles using an automatic transmission will use a positive gear lockout.
84. All automatic transmissions must have an approved safety blanket over the torque converter area. A full length safety blanket is required. Automatic transmission shield or tractor blanket must meet SFI Spec. 4.1

**ANY OTHER RULES REFER TO THE PPL RULE BOOK**

## GENERAL TRUCK RULES

### A- LIMITED PRO DIESEL 4X4 TRUCK 3.0

**All Vehicles Must comply to  
“General and Safety Rules”**

***\*\*\* Please refer to the PPL Rulebook for  
updated 2.6 rules.***

1. Maximum weight 8000lbs.
2. The OEM chassis is mandatory. The vehicle must retain the full OEM chassis. Wheel tubs, back- half conversions, tube chassis are prohibited. Maximum wheelbase 158” and 102” maximum width (outside tire to outside tire.) Rigid suspension allowed. Hydraulic steering is allowed.
3. The body must be an OEM truck body, including the complete OEM floor pan and must retain complete OEM firewall. Complete bed floor, hitch is allowed to protrude thru the bed floor w/minimum amount of floor removed. No flatbeds permitted. The body must retain the full sheet metal, aftermarket steel hoods are permitted. The hood must be closed and securely latched while hooked to the sled.
4. Maximum engine size will be 460 cubic inch. Engines must come from factory in one ton or smaller diesel pickup truck. Engine must remain in stock location as intended by manufacturer. Engines may be interchanged between manufacturers.
  - a. No aftermarket blocks permitted.
  - b. Head must be OEM or OEM one piece cast replica for that brand engine. No billet heads of any material. Outside dimensions of cylinder head must measure factory width and length. Head must retain OEM valve angle.



5. Front of engine block can be no farther forward than 17" of center line of front axle.
6. Engine must have cable surrounding block and head. Cable must be minimum 3/8" diameter located between cylinders #1 and #2. Cable must pass thru manifolds. Cable will have 4-6" of slack with a minimum of 4 cable clamps at splice.
7. All engines will have a deflection shield, running the complete length of the block casting. Shield must be securely fastened and must be .060" thick. (This equates to a steel inner fender)
8. Hook point must be no closer than 44" of center line of rear axle, hitch height maximum of 26", with a minimum of a 3.75" X 3.0" opening. Hitch point must be easily accessed. No "trick" type hitches permitted. Hitch must be stationary in all directions. Hitch must be frame mounted. Hitch must be mounted center line of rear axle or behind. Hitch must not exceed a maximum of 25° angle from pivot point to hook point. No hitch supports or adjusters, if fastened to the rear axle housing shall be above the center line of rear axle. Pivot pin of drawbar can be no farther forward than center line of the rear axle.
9. Secondary hitch required. Minimum of 3/8" steel, located 12" below primary hitch on the same vertical plane. (You should be able to look directly through both at the same time – they need to be lined up.)
10. The turbocharger is smooth faced intake housing, limited to a 3.0" inlet, (no map ring) with all air entering through the 3.0" opening. Intake wheel must protrude 1/8th inch inside of opening.
11. Exhaust must exit straight up, with (2) 3/8" bolts mounted in a cross pattern no more than 1" apart as close to the turbine wheel as possible, no more than 6" away from turbine wheel.

12. Intercoolers allowed. Dumping or draining intercoolers without a catch pan within 100 feet of competition track is prohibited.
13. Water injection is prohibited. All components must be removed from the truck.
14. Air shut off must have a cable that goes to the rear of truck operated by the sled operator and also one to the cab of the truck. Kill switch will be securely mounted to the back of the vehicle and have a two (2) inch diameter metallic ring to attach the sled.
15. Fuel Systems: Maximum of one P7100 pump, limited to one plunger per cylinder. The use of multiple high pressure common rail fuel pumps is allowed. Ford Powerstroke engine may utilize a second HPOP. Electronic fuel injection is permitted. A 3-way dump valve mounted before the injection pump is mandatory which can be operated by the driver while strapped in the seat.
16. No fuel lines or tanks permitted inside of truck cab unless securely mounted in marine box.
17. Fuel limited to diesel fuel. No alcohol, nitrous, propane or any oxygen enhancing agents allowed.
18. Must run DOT approved tire. Maximum tire height 35", no studded tires or chains. No alteration to DOT tires allowed. Dual rear wheels are permitted on rear axle only. Maximum of 6 tires.
19. Front weights must be no more than 60" from the center line of the front axle to forward most point and be securely fastened. No weights are allowed in cab of the truck. If weights are located in the bed of truck they are to be securely fastened to the bed of the truck.

20. Drive train will consist of the following: Any front axle, any transfer case and any rear axle. No planetaries permitted.
21. Axle shields are required. Shield to be .060" thickness steel or aluminium. Shield not to be mounted to axle ends or hub bolts. A hole may be cut in one to allow locking in of hubs.
22. No cast iron clutches or flywheels permitted, must be SFI approved. Trucks with automatic transmissions, refer to General Rules.
23. SFI bellhousing blankets and/or SFI blow proof bellhousing required.
24. All U-joints must be shielded 360 degrees with 3/8" thick aluminium w/1/8" steel liner or 5/16" thick steel. Shield will be 6 inches long minimum and centered on u-joint. Inside diameter of shield will be no more than 2 inches larger than u-joint.
25. All intermediate shafts between the transmission and transfer case will be totally enclosed in 3/8" aluminium or 5/16" steel, 1/4" of shaft may be visible.
26. Fire extinguisher (2.5#) or fire suppression system, Helmets-Snell 90 or better, SFI fire suits, head sock, gloves, shoes, and seatbelts required.
27. All other rules may be found in 4X4 Truck and General Rule sections.
28. Allow removing the bed out of the box, box must have bed cover.

## **B - PRO STOCK PICK-UP RULES**

### **All Vehicles Must comply to “General and Safety Rules”**

#### **WEIGHTS & WHEELS**

1. Tires must be street legal. No tread alterations of any kind-sharpening, cutting, re-grooving, or tread touch up is not allowed. No larger than 33 x 12.50 x 16 or 305 x 16 only DOT approved with factory stamp. The size must be displayed on the tire.
2. Solid rear suspension allowed.
3. Any rear-end housing size is permitted. Maximum of one-ton front-end housing allowed. No air lockers or electronic locking devices. The width of the housings is to be like the width of the factory housings.
4. Weights/weight bar must not extend forward more than sixty (60) inches from the centerline of front axle

#### **ENGINE**

1. Engine must be the same make as vehicle. Engine must be in stock location. Rear edge of block to center of axle can be no less than 14". May only run cast iron blocks with any cast iron heads or aluminum type heads also acceptable are NHRA pro stock legal with wedge shaped combustion chambers, no hemi type chamber (can have spark plug in middle through valve cover), OEM or after market. Any internal engine modification allowed.
2. Any single 4-barrel manifold required naturally aspirated. Sheet metal intake manifolds are allowed.
3. A 1% variance to the engine limit of 485 cubic inches.
4. Maximum engine bore spacing of 4.9 inch.
5. No electronic timing devices.
6. No traction control, no digital boxes.

## **BODY/CHASSIS**

1. All body components must have factory production OEM frame.
2. Vehicle must retain original wheelbase plus or minus ½ inch and stock appearance, 133" maximum.
3. Hood scoops optional.

## **HITCH**

1. Any nonmember or puller that doesn't conform to rules shall lose 2 inches of hitch height. Or 200 pounds of weight by their choice.

## **DRAWBARS**

1. Primary hitch must be secure to vehicle frame in all directions, Hitch stem may be any length, as long as point of hook is not less than 36% of wheel base.
2. Hitch point to rear axles centerline must be a minimum of 36% of wheelbase. This distance cannot change during the pull.
3. Hitch stem angle must not exceed 25 degrees measured on the stem w/angle finder. Main stem must be straight from point of hook to pivot point. (On the same plane).
4. No part of hitch can be attached or come into contact w/ rear axle during pull except the Stem adjuster.
5. Hitch adjuster must not locate more than 6 inches from point of hook.
6. Hitch height cannot exceed 26 inches from point of hook to ground or track.
7. No "L" shaped drawbars.
8. No drawbar angle greater than the angle of the sled chain. Acceptable angle is 0 degree to a maximum of 20 degrees. This will be measured by the angle of a straight edge from the point of hook to the center of the pivot point.
9. All turn buckles that control drawbar height from BELOW the drawbar must be vertical or angle FORWARD from the attachment point on the drawbar to axle housing. Attachment point on axle cannot be above centerline of axle housing.

## **DRAWBARS (CONT)**

10. All turn buckles that control drawbar height from ABOVE the drawbar must be vertical or angle BACKWARD from attachment point on drawbar to frame.
11. Maximum hitch height shall be 26 inches. This maximum cannot change during pull.
12. Drawbar to be made of steel, minimum of two (2) square inches' total material at any point. This will include the area of the pin with pin removes. Pins will be minimum of 7/8-inch diameter. Drawbar must be equipped with steel hitching device constructed of not more than 1 ½ inch square nor less 1-inch square (1 1/8-inch round stock) with an oblong shaped hole of 3 ¾ inch long by 3 inch wide.
13. No cam type rear ends. All rear ends must be welded or bolted by a minimum of 3 bolts per side solid with a minimum of 3 5/8 grade 5 bolts per side to the frame.

## **TRANSMISSION**

1. Aftermarket transmission and transfer case allowed.

## **FUEL AND WATER**

1. Alcohol fuels and propylene oxide are not allowed.
2. VP Fuel and water only with all vehicles. A \$50 fine will be assessed for lack of fuel and water test ports for all classes. Also, for any minor infractions of fuel or water quality. Each vehicle must display 2 VP Racing Fuels decals one on each side.

**MEMBER MUST ATTEND AT LEAST 50% OF THE HOOKS TO SUBMIT A RULE CHANGE REQUEST.**

## GENERAL TRACTOR RULES

1. Turbo chargers that are not under a hood must be completely shrouded, except for inlet and exhaust pipes, with steel or aluminum at least .060 thick.
2. No superchargers will be allowed unless factory equipped.
3. Tractor must have either: 1. Safety tie bars mounted to rear axle housing with at least 4 axles housing bolts and extending forward to flywheel area and fastened to side of block or main frame with at least two 5/8-inch bolts. OR 2. A one piece frame extending from the front of the tractor to the rear axle housing mounting bolts. All safety blankets must be mounted inside safety tire bar system or one-piece frame.
4. All tractors are required to have an approved bell housing blanket that meets the following specifications: 20 ply ballistic nylon or 20 ply Kevlar style 713 betting construction. At least seventeen (17) inches wide and long enough around the bell housing to have six (6) inches of overlap, overlap goes to the bottom, secured with a two (2) inch wide nylon web straps, with a steel "D" ring on one end and swen the length of the blanket, except overlap area and long enough to pass back through the "D" ring and to be tied in a saddle cinch and with four (4) two inch nylon webs retaining strips, each at the front and back of blanket.
5. All tractors must have a metal fire shield between engine and operator. Shield may be a one, two or three piece shield, secured every two inches at the seam with a minimum of 1/8" fasteners; if openings are necessary, Keep as small as possible and seal opening with high temperature sealer or equivalent. Shield maybe constructed of a sheet of metal and/or aluminum, minimum thickness of .60.
6. Deflection shields are required on both sides of the engine from the bottom of the head and extend to 2" below bottom center throw of crankshaft.

7. All tractors must be equipped with a starter interrupt switch on the gearshift that will allow start engagement only in neutral gear position.
8. Maximum length of tractor wheelbase can be 114 inches from center of rear axle to center of front axle. Engine block may be repositioned a maximum of 1" forward to original. Maximum length of tractor can be 14 feet from center of rear axle to furthestmost point of front weights.
9. Cross bolts are required in exhaust outlet. Bolts are to be positioned at a 90-degree angle to each other and at a maximum of 1" apart as close to the turbo as possible. Bolts must be at least a grade 5. Exhaust must discharge vertically; no rain caps, no curved outlets on pipes.
10. Harmonic balancers that are non-SFI approved shall be shrouded with ¼" steel no more than 1" away in any direction of rotation, 360 degrees and securely fastened, or shall be solid steel. A bolt in the crankshaft to hold the dampener is required. All balancers or steel hubs require having a retainer to restrict forward movement.
11. All tractors must be equipped with a kill switch. For the diesels, it must be an air shut off; for spark ignition engines it must be a complete ignition shutoff. Kill switch must be located a maximum of four feet above the drawbar, 6' in any direction. For air kills the cable must be enclosed, so that if the tractor un-hooks from the sled cable can be separated from the tractor without obstruction from the tractor. Ignition and/or air must be able to be killed from the driver's seat.
12. A dead man throttle is required. Spark ignition engines must utilize a return spring on the butterfly shaft. Diesel engines must utilize a return spring on the fuel injection pump speed control lever. Return springs utilized must function in such a manner that if the operator's control cable and/or linkage fails or comes unhooked, positive return to low idle position will occur. Throttles will work in a reverse to forward motion, reverse being closed.



13. Drawbar will be an 18" minimum length from the center of rear axle to hook point, maximum of 1 ½" from back of hole to rear of drawbar. Minimum specifications: 1" thick material around 3" wide drawbar hole hook point. (Refer to illustration on page 40). All hooks must drop from the top. Overall construction to be discretion of rules officers. Drawbars must be rigid in all directions.
14. Shielding on v or y type engines must be from the base of the head to two inches below the crankshaft throw. Frame may be used as all or part of the shield provided it is solid and covers the required area. Shielding in-line engines will run from hood to two (2) inches below the crankshaft throw. Shield must be complete, no holes accepted. Shielding must extend complete length of the block and be securely fastened. All engines will have a deflection shield, running the complete length of the block casting. Shield must be securely fastened and must be .60 inch thick. Starters, exhausts, fuel pumps, etc., will not be considered as part of the shield.
15. Fenders are mandatory and must be a minimum of 2" above the top of the tire. They must extend outward 2" over the tire, with a minimum fender length of 30".
16. SFI roll cages are required for all tractors.
17. Tractors must have a wide front end.
18. All tractors must have brakes.
19. All tractors must have a strong rigid seat that is independent from the fenders.
20. No portion of the tractor, including weights, may exceed 14 feet forward of the center of the rear axle.
21. Legal fuels are gasoline, alcohol, aviation gas, kerosene and diesel.

22. Flywheel must be steel or aluminum. No cast iron flywheels allowed. No cast iron or gray iron pressure plates. Floater plates must be steel.
23. Water injection will be allowed. No alcohol, alcohol based substance, additive and/or formula containing alcohol of any kind of manner may be used or allowed in water injection. Water pump lubricants allowed.
24. No fuel additives allowed.
25. On cast OEM tractors, a 1/2 steel spacer plate is permitted.
26. All turbo charged engines will have on cable total surrounding engine block and cylinder head. The cable will consist of a minimum of 3/8 dia. cable or located between first and second cylinders. Cable must have (4) to (6) inches of slack, minimum four cables of slack.
27. Any 4.1 turbo or larger compressor housing must be wrapped with Kevlar style blanket.

**ANY OTHER RULES REFER TO THE PPL RULE BOOK**

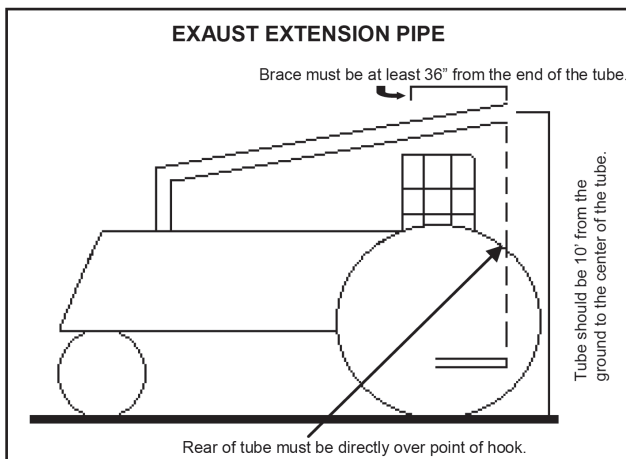

## **SUPER FIELD TRACTOR RULES**

### **All Vehicles Must comply to “General and Safety Rules”**

1. Max OEM cubic inch 466 @ 3200 RPM, 466 – 504 OEM cubic inch at 2800 RPM (ie- Case 504).
2. Max tire size – 20.8 X 38. Cut tire optional.
3. OEM stock head for that model or series of engine.
4. OEM stock intake & exhaust manifold (spacers allowed 1” maximum). Great Plains and Northeast NE rules.
5. Water Injection & Ice boxes NOT permitted.
6. Any MM A pump (Any pump –P or less)
7. Stock out of the box 3LM-466 turbo with no alterations to any internal wheels, housings, or shafts.
8. All tractors to be equipped with a Data Log RPM sensor. Female 110-volt receptacle on back of tractor. Plug in must be within 12” of Kill Switch for easy access.
9. Ruling for going over RPM limit;
  - 1<sup>st</sup> - Dropped to last place points
  - 2<sup>nd</sup> - No Points & No Money that hook.
  - 3<sup>rd</sup> - Banned from association for 1 year plus 1 day from date of violation.
10. Tractors to be equipped with steel fly wheel, steel clutch components & clutch blanket.
11. Tube frames allowed
12. Fuel: VP DX fuel mandatory.
13. Test ports mandatory.

## **B - 466 LIMITED PRO STOCK TRACTOR RULES**

### **All Vehicles Must comply to “General and Safety Rules”**

1. Maximum weight permitted 8500 lbs.
2. Maximum cubic inch 470. OEM cylinder heads. Aftermarket manifolds permitted.
3. NO intercoolers.
4. Maximum 7100 P-pump. Maximum 13 millimeter plungers.
5. Turbo-Smooth bore 3.00” intake and slotted cover MWE Map Width Enhancement which must protrude in to the housing are permitted. Pullers running the Outlaw 8500 limited pro turbo must leave access so inspection can be done to find the outlaw logo on the fins of the turbo.
6. Maximum tire size 24.5. 20.8X38 tires allowed. Radials allowed.
7. All fluids are subject to a diagnostic screening which includes but not limited to, specific gravity, mass spectrometer, oxygen concentration and burn test.
8. Diesel fuel standards for PPL dielectric constant test are greater than 30 and less than 100. Any mixture of diesel fuel, upper cylinder treatments, cetane, etc that does not fit into the required standard will be disqualified.
9. All other Super Stock OEM chassis and safety rules apply.
10. Fuel: VP DX fuel mandatory.

## C - SUPER FARM TRACTOR RULES

### All Vehicles Must comply to “General and Safety Rules”

1. No engine larger than 640 CID (plus or minus 1%).
2. Engine head must be OEM agricultural type for that brand engine. Recast heads allowed with OEM dimensions.
3. No overhead cams allowed.
4. OEM stock intake and exhaust manifold for that series engine.
5. 1 turbo for Super Farm and new class 466.
6. PRECISION TURBO 3X3.35 or 3X3 allowed.
7. Intake manifold may only be modified for mounting and attaching turbo inlet pipe.
8. A maximum 1 inch spacer plate between head and intake manifold allowed.
9. Only p7100 or p3000 or 8000 series injection pump's allowed with any plunger size.
10. Only VP DX Fuel.

**NOTE:** Alterations for turbo mounting allowed. A spacer no larger than 3 inches allowed between the turbo and exhaust manifold. No modifications of the exhaust manifold allowed on the outside.

## D - LIGHT SUPER STOCK TRACTOR RULES

### All Vehicles Must comply to “General and Safety Rules”

1. Weights: 6100lb 505ci alcohol single 4.6 and multi charger tractors. 6400lb 640ci 4.8 turbo diesel, multi charger diesel, LLSS 400ci or less alcohol, 410ci diesel with intercooler.
2. Cummins power plant allowed in Oliver application. LLSS intercooler allowed on 300ci twin charger.
3. Only engine considered legal to be used in super stock division must be available in two wheel drive farm tractors. (This applies to both OEM and component type.)
4. Maximum of one (1) inch deck plate between bottom cylinder head and top of engine block. A maximum allowance of .130 total gaskets with a maximum of 640 cubic inch total. No deck plate may be utilized on engines larger than 640 cubic inches with the exception of the unlimited super stock class.
5. No plates allowed between cylinder head (jug assembly) and crankcase, i.e., Duetz-Allis, Minneapolis, etc.
6. Light super stock class limited to 505 CID, Only two (2) valves per cylinder must be parallel with each other and parallel within 15 degrees of cylinder wall. OEM canted valve heads allowed.
7. OEM heads or two (2) valve aftermarket heads allowed, No operating inner coolers allowed.
8. No over head cams or hemi-style heads allowed in the light super class.
9. Tires no more than 30 ½ inches wide.

9. 400 series IH engine with 656 style rearends, 466 series Allis with 180 style rearends are allowed. Must retain factory (OEM) clutch housing, transmission case, rear end housing, and axle housing.
10. Rim diameter limited to 32 inches on tire widths over 24 ½ inch.
11. Tractor must retain cast iron integrity from engine block to rear end, allowing cutting transmission and clutch inspection, must remain rigid. If the cast case is broken this means it has lost integrity. It needs to be replaced before future competition. Excessive lightening causing safety concern to be reviewed by board and class for approval.
12. Draw bar angle not exceed 10 degrees up or down and remain ridged in all directions.
13. No HP pullers tires in the light super stock class.
14. No component tractors in the light super stock class.
15. Maximum size of injection pump is a P-pump or Sigma with no limitation on plunger size.
16. 510 to 640 cubic inch engines are limited to one 4.8-inch turbocharger.
17. All ether bottles (starting aides) must be placed outside of the engine compartment.

## **E - 640 LIMITED PRO STOCK TRACTOR RULES**

### **All Vehicles Must comply to “General and Safety Rules”**

1. Maximum cubic inch limit is 640.
2. The only acceptable fuel(s) is diesel and biodiesel fuel.
3. The turbocharger can either be smooth-faced intake housing, limited to a 4.1” inlet, with all air entering through the 4.1” opening. Intake wheel must protrude 1/8th inch inside of opening. No slugged down turbo allowed. All slotted chargers must have a cast wheel. All exhaust will exit through a 4.5” opening in the exhaust housing. Exhaust wheel must protrude 1/8th inch inside of opening.
4. No waste gates permitted.
5. No air cooling devices in any manner permitted.
6. Maximum size injection pump allowed is a 7100 series pump (2 5/8”W x 9 9/16”L x 8 3/16”H main pump body), only one plunger per cylinder.
7. Component chassis are not acceptable.
8. No overhead cams permitted. Outside of cylinder head must keep OEM length and width dimensions. Valves must retain OEM angle. Manifold bolt pattern (stock location).
9. Aftermarket manifolds are allowed and must bolt in original port bolt pattern.
10. Deck plates are allowed with a maximum thickness of 1 inch.
11. No overhead-cams permitted.
12. Maximum 2 valves per cylinder.
13. Maximum tire size is 24.5” X 32”.



## **F - UNLIMITED SUPER STOCK TRACTOR RULES**

### **All Vehicles Must comply to “General and Safety Rules”**

1. Only engine considered legal to be used in super stock division must be available in two wheel drive farm tractors. (This applies to both OEM and component type.)
2. Cast rear-end tractors using a single turbocharger will weigh 7500lb. Components rear-end tractors will weigh 6500lb. Component diesel can weigh 6700lb. Cast rear-end tractors using multiple turbochargers weigh 7000lbs.
3. 1/8” inch cable must be wrapped around stages with multiple turbochargers. Cable must wrap revolutions around turbo(s), clapped by a minimum of two clamps at splices. (ex engine cable.)
4. Maximum wheelbase is 114” inches and maximum length is 13’ foot from the center of the rear axle to forward most part of the tractor.
5. Front nose of the crankshaft can be no lower then 4” inches of the center of the rear axle.
6. Class is “unlimited” but must comply with all safety rules listed under the general and unlimited safety rules that apply.
7. No Electronic fuel injection.
8. Maximum tire size not to exceed 30.5 X 32.
9. Engine management system permitted. Only mechanical intake and exhaust valve control operation permitted.

# GENERAL MODIFIED RULES

## A - MODIFIED TRACTOR RULES

### All Vehicles Must comply to “General and Safety Rules”

1. Weight is 6000lbs no tolerance unless noted otherwise.
2. Allowable fuels, alcohol, diesel, kerosene, any form of gas/race gas, absolutely no nitro methane or nitrous oxide allowed.
3. EFI is allowed on any engine combination listed below.
4. Maximum of one 600ci hemi headed v8 automotive style engine with maximum blower size of 14-71, no screw blowers allowed.
5. One fuel injected Allison v12 aircraft engine limited to 8.8-1 supercharger overdrive ratio.
6. One carbureted gas Allison v12 aircraft engine limited to 9.6-1 supercharger overdrive ratio.
7. One carbureted gas Merlin or Packard style v12.
8. Any combination of N/A wedge head automotive style engines with a combined displacement of 1500ci.
  - A. Under 710ci will be allowed to run at 7000lbs.

9. Any combination of forced induction wedge head automotive style engine with combined displacement of 750ci air forced induction.
  - A. Turbos limited to one per bank 76mm inducer compressor side, 76mm exducer turbine side for aluminum headed engines and 88mm inducer compressor side, 88mm exducer turbine side for cast iron heads.
  - B. Under 355ci will be allowed to run at 7000lbs.
  - C. Any type of engine driven blower excluding screw type no over drive limit no variable speed device.
  - D. No intercoolers allowed.
  
10. One Ag or industrial style engine with any 4.1" inducer compressor side, 4.1" exducer turbine side turbo, limited to 505ci displacement on alcohol and unlimited displacement on diesel. Aftermarket aluminum heads allowed no overhead cams or hemi style combustion chambers.
  
11. One Lycoming T53 L13 turbine at 6200lbs.  
Twin Lycoming L-1, L-11 allowed military specifications.  
NO WATER INJECTION.
  
12. Any combination of automotive style diesel engines limited to 900ci displacement may run one turbo per engine limited to 3" inducer compressor side and 3.5" exducer turbine side. No intercoolers, Water injection is allowed.
  - A. Under 450ci will be allowed to run at 7000lbs
  
13. One 1100ci Ford GAA engine on alcohol limited to two non-staged turbo chargers.

## B - TURBINE MODIFIED RULES

### All Vehicles Must comply to “General and Safety Rules”

1. No turbine engine is allowed to run a clutch/flywheel assembly or any automatic transmission.
2. Exhaust pipes on turbines must extend a minimum of 6 inches about the top of the exhaust opening.

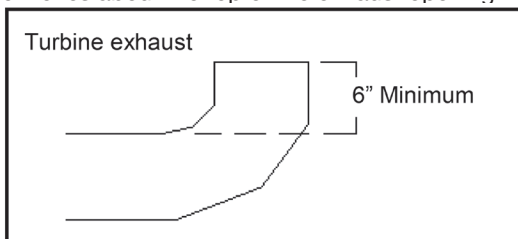

3. Exhaust stack diameter to be no smaller than 1 inch of engine outlet.
4. No turbine engine will be operated beyond military temperature and RPM limits.
5. Turbine air intake must be screened with metal screen that has openings no larger than 3/16-inch.
6. Turbine engines must have a 3/8" steel shroud that surrounds the engine. Shroud must extend a minimum of 5 inches forward and ten inches of the turbine section. The shroud must incorporate a minimum of 3/8 inch thick flanges that extend radially inward from the shroud on both ends of the shroud with a maximum of 1 inch of the engine casing. A 1/2 inch gap between the engine and the ID of the flange must be maintained for air circulation inside the shroud. The flanges may be scalloped out to clear turbines accessories, brackets, etc. And maybe either rolled edged of the shroud or steel rigs attached by welding or riveted to the shroud.

7. Two independent over speed protection devices are required for power turbine wheel.
8. The governor setting must not exceed manufacturer's maximum specs. Over speed shutdown-consist of speed monitor that activates a normally closed solenoid valve located between the fuel control and fuel manifold. Trip setting to be low enough to prevent over speed in event of driveline failure. No TF-35 engine allowed.
9. Turbine engines allowed starter motor onboard or auxiliary power unit to be carried onboard and running during a competitive attempt but must not be hooked into the drive train during competition attempt.
10. Any specifications not listed refer to PPL turbine rules.

# STABILIZER BARS

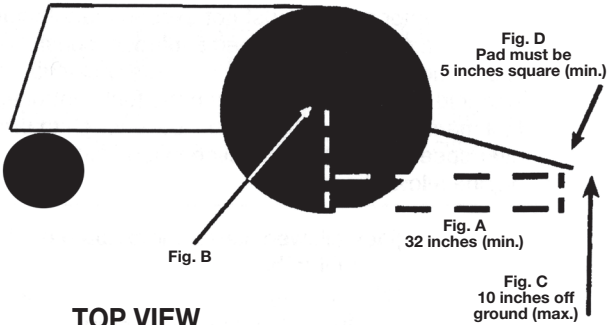

## TOP VIEW

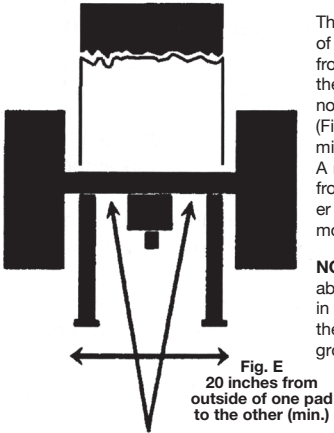

The stabilizer bar will extend a minimum of 32 inches behind a line (Fig. A) drawn from the center of the wheel (Fig. B) to the ground. The stabilizer pad must be no more than 10 inches off the ground (Fig. C). The stabilizer pad must be a minimum of five inches square (Fig. D). A minimum of 20 inches will be allowed from the outside of one pad to the other (Fig. E). Stabilizer bars are not to be mounted in any way to the drawbar.

**NOTE:** The stabilizer bar system must be able to support the weight of the tractor in the heaviest class pulled. Jacking up the pads so tractor is completely off the ground is a good test.

The stabilizer bars and their assembly are in no way to be connected to the drawbar or its assembly.

## DRAWBAR RULES

1. Mandatory drawbar height check will be done at the scales before each pull attempt. This applies to all NBPI vehicles.
2. Drawbar can be no higher than 20" inches for tractors and 26" inches for trucks off the ground during a pulling attempt.
3. All vehicles are required to have a safety hitch. Safety hitch must be as strong as primary hitch and cannot be connected to the primary drawbar. Safety hitch must be mounted eight (8) inches below primary on all tractors and twelve (12) inches below primary for all trucks.
4. Primary drawbar must be painted orange and secondary (safety) drawbar must be painted white.
5. Draw Bar specs are listed below.

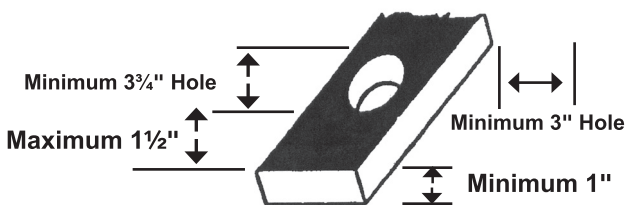

**HOOK MUST FREE FALL**

# BY-LAWS OF NEBRASKA BUSH PULLERS, INC

By-Laws wrote on April 1, 1989  
Amended on September 22, 2002

## ARTICLE I - OFFICES

The principal office of the corporation in the State of Nebraska shall be located at RFD#1, Syracuse, NE 68446. The Corporation may have other offices, either within or without the State of incorporation as the board of directors may designate or as the business of the corporation may from time to time require.

## ARTICLE II - MEMBERSHIP

A member of the Nebraska Bush Pullers, Inc. is defined as a person who has reached the age of sixteen years and has paid all membership dues. The membership dues shall be paid annually. The executive committee consisting of the Chairman of the Board, President, Vice President, Secretary, and Treasurer have the right to accept or decline any membership. The executive committee shall not provide any just cause for the acceptance or denial, other than passed by a majority vote. This applies to any person, tractor, or combination thereof. This ruling shall be in effect for a period of one year.

## ARTICLE III – ANNUAL MEETING

1. The annual meeting of the members shall be held within sixty days of the last sanctioned pulling event of each calendar year beginning with the year 1989 and the time and place to be determined by the board of directors for the purpose of nominating officers and for the transaction of such other business that may become before the meeting.



2. Special Meetings of the members for any purposes unless otherwise provided by statute, may be called by the president at the request of the members or board of directors.
3. The officers may designate any place either within or without the State unless otherwise prescribed by statute, as the place of meeting for any annual meeting or for any special meeting called by the officers. A waiver of notice signed by all members entitled to vote at a meeting may designate any place either within or without the State, unless otherwise prescribed by statute as the place for holding such meeting. If no designation is made, or if a special meeting be otherwise called, the place of meeting shall be the principal office of the corporation.
4. Written or printed notice stating the place, day and hour of the meeting and, in case of a special meeting, the purpose of purposes for which the meeting is called, shall be delivered not less than one week before the date of the meeting by mail, by or at the direction of the president or the secretary, or the officer or persons calling the meeting. When mailed, such notice shall be deemed to be delivered when deposited in the United States Mail, addressed to the members at his address as it appears on the membership list of the corporation, with postage thereon prepaid.
5. The voting list shall consist of the members who have paid their dues during the current calendar year.
6. A simple majority of the voting members present at the meeting shall constitute a quorum at the meeting of the members. The members present at a duly organized meeting may continue to transact business until its adjournment, notwithstanding the withdrawal of enough members to leave less than a quorum.
7. Proxies - No proxies written or verbal shall be authorized to vote at any meetings.

8. Each member who has paid their dues in the calendar year shall be entitled to a vote in accordance with the terms and provisions of the certificate of incorporation and shall be entitled to one vote, in person, for each membership. Upon demand of any member the vote of officers and upon any question before the meeting shall be by ballot. All elections of the officers shall be decided by a majority vote except as otherwise provided by the certificate of incorporation or the laws of this State.
9. The order of business at all meetings of the membership shall be as follows:
  1. Roll Call
  2. Proof of notice of meeting or waiver of notice
  3. Reading of minutes of preceding meeting
  4. Reports of Officers
  5. Reports of Committees
  6. Nomination of officers to be elected at the annual rules meeting
  7. Unfinished business
  8. New business

## ARTICLE IV – BOARD OF DIRECTORS

1. GENERAL POWERS  
The board of directors is vested in the full power to change a rule at anytime for the betterment of the club. They have full power and authority to be put into effect the laws, resolutions and decisions of the voting with such other powers as may be set forth hereinafter. All Board of Directors must agree with unanimous vote.
2. NUMBER, TENURE AND QUALIFICATIONS  
The number of board of directors shall be composed of the officers of the corporation, immediate past chairman and each director shall hold office until the next annual meeting of the stockholders, or until his successor shall have been elected to qualify.

3. RESIGNATION

A director may resign at any time by giving written notice to the board, president or secretary of the corporation. Unless otherwise specified in the notice the resignation may take effective upon receipt thereof by the board of such officer, and the acceptance of the resignation shall not be necessary to make it effective.

4. COMPENSATION

No compensation shall be paid to the directors, as such, for their services, but by resolution of the board a fixed sum and expenses for actual attendance at each regular or special meeting of the board may be authorized.

5. EXECUTIVE AND OTHER COMMITTEES

The board, by resolution, may designate from among its members and executive committee and other committees, each consisting of one or more directors. Each such committee shall serve at the pleasure of the board.

## ARTICLE V – OFFICERS

1. NUMBER

The officers of the corporation shall be a President, Vice President, Secretary, Treasurer and Chairman of the Board, each of whom shall be elected by the members. Such other officers as may be deemed necessary may be elected by the members or appointed by the membership of board of directors.

2. ELECTION AND TERM OF OFFICE

The officers of the corporation to be elected by the membership shall be elected annually at the business meeting held prior to the Awards Banquet. Each officer shall hold office until his successor shall have been duly elected and shall have qualified or until his or her death or until he or she shall resign or shall have been removed in the manner provided herein.

### 3. REMOVAL

Any officer or agent elected or appointed by the member of board of directors may be removed by the members of the board of directors however in their judgment the best interests of the corporation would be served thereby.

### 4. VACANCIES

A vacancy in any office because of death, resignation, removal, disqualification or otherwise, may be filled by the officers of the unexpired term of the president.

### 5. CHAIRMAN OF THE BOARD

The immediate past President of the corporation shall be designated the Chairman of the Board and shall assist the President with matters concerning the corporation and shall be a voting member of the Board of Directors.

### 6. PRESIDENT

The President shall be the principal executive officer of the corporation and subject to the control of the members and shall in general supervise and control all the business and affairs of the corporation. He shall, when present, preside at all meetings of the corporation, and may sign with the Secretary or any other proper officer of the corporation thereunto authorized by the membership, contracts or other instruments which members have authorized to be executed, except in cases where the signing and execution thereof shall be expressly designated by the officers or by these by-laws to some other officer or agent of the corporation, or shall be required by law to be otherwise signed or executed; and in general shall perform the duties incident to the office of the President and such other duties as may be prescribed from time to time. The President shall be nominated from the current years officers.

7. VICE PRESIDENT

In the absence of the President or in the event of his death, or refusal to act, the Vice President will perform the duties of the President and when so acting shall have all the powers of and be subject to all of the restrictions upon the President. The Vice President shall perform such other duties as from time to time may be assigned to him by the President of the membership.

8. SECRETARY

The Secretary shall keep the minutes of all meetings in one or more books provided for that purpose, see that all notices are duly given in accordance with the provisions of these by-laws or as required, be the custodian of the corporate records and of the seal of the corporation, and keep a register of the post office address of each member, which shall be furnished to the Secretary by such member and in general perform all duties incident to the office of the Secretary and such other duties as from time to time may be assigned to him by the President.

9. TREASURER

Treasurer shall have the charge and custody of and be responsible for all funds and securities of the corporation; receive and receipt for moneys due and payable to the corporation from any source whatsoever, and deposit all moneys in the name of the corporation in such banks, trust companies or other depositories as shall be selected in accordance with these by-laws and in general perform all of the duties incident to the office of Treasurer and such other duties from time to time may be assigned to him by the President.

10. SALARIES

No Salaries shall be paid to anyone of the officers of the corporation.

## ARTICLE VI – CONTRACTS, LOANS, CHECKS AND DEPOSITS

### 1. CONTRACTS

The President is authorized to enter into any contract or execute and deliver any instrument in the name of and on behalf of the corporation, and such authority may be general or confined to specific instances.

### 2. LOANS

No Loans shall be contracted on behalf of the corporation and no evidences of indebtedness shall be issued in its name.

### 3. CHECKS, DRAFTS

All checks, drafts or other orders for the payment of money, or other evidence of indebtedness issued in the name of the corporation, shall be signed by officer or officers of the corporation in the manner as shall from time to time be determined by resolution of the membership.

### 4. DEPOSITS

All funds of the corporation not otherwise employed shall be deposit from time to time the credit of the corporation in such banks, select trust companies or other depositories as the officers may select. The initial depository shall be Bank of Norfolk, Norfolk, NE.

## ARTICLE VII – MEMBERSHIP

Cards representing membership and payment of dues of the corporation shall be in such form as determined by the directors, Such certificate shall be signed by the Secretary and any other officer authorized by law. The name and the address of the member and the date of payment of duties shall be entered of the membership and voting list of the corporation.

## ARTICLE VIII – FISCAL YEAR

The fiscal year of the corporation shall begin on the first day of January and shall end of the 31st day of December in each year.

## ARTICLE IX – DIVIDENDS

No dividends shall be paid by the corporation, nor shall any act be done which would be inconsistent with the provisions of Section 501C3 of the Internal Revenue Code, 1954 as amended that would render the non-profit corporation ineligible from federal income tax.

## ARTICLE X – SEAL

The directors shall provide a corporate seal, which will be circular in form and shall have inscribed thereon the name of the corporation, the state of incorporation, year of incorporation and the words “Corporate Seal”.

## ARTICLE XI – AMMENDMENTS

These by-laws may be altered, amended, or repealed and new by-laws my be adopted by a vote of the membership representing a simple majority of all members at any annual membership meeting, or at any special meeting, when the proposed amendment has been set out in the notice of such meeting.

